



USE AND INSTALLATION INSTRUCTIONS

Window (room) air conditioner

HCB09

HCB12







Thank you very much for purchasing a **Hisense** air conditioner, please read this User Manual carefully before installing and using this appliance and keep this manual for future reference.





CONTENTS

Safety precautions	2
Part names	3
Operating instructions	5
Maintenance	8
Operation tips	9
Electrical specifications	10
Troubleshooting	11
Installation instructions	12

Safety Precautions

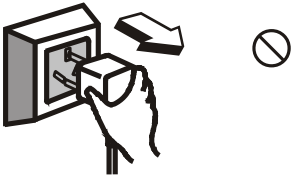
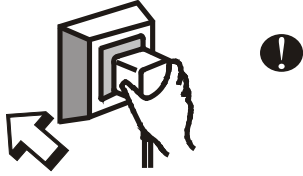
Symbols in this User's Manual are interpreted as shown below:

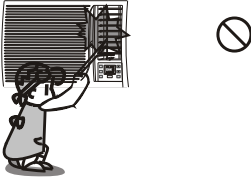
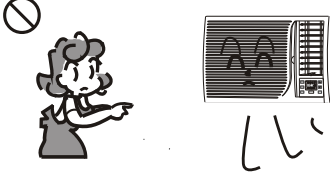
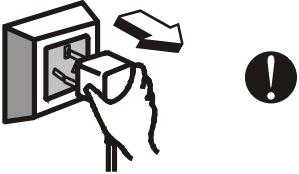
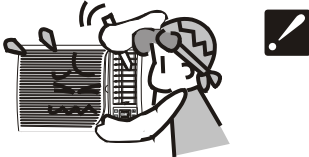
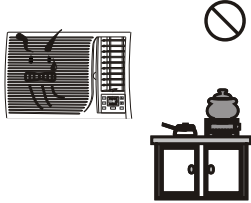
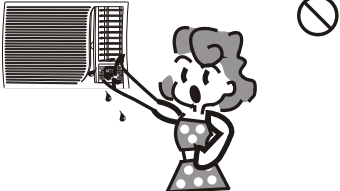
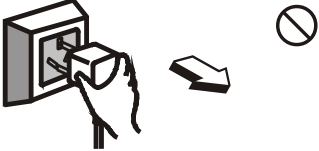
-  Be sure not to do.
-  Be sure to follow the instruction.
-  The feature of the appliance, instead of a fault.
-  Grounding is necessary.
-  Pay attention to such a situation.
-  Warning: Incorrect handling could cause a serious hazard, such as death, serious injury, etc.

 <p>Do not use the power supply circuit breaker or pull off the plug to turn it off during operation. This may cause a fire due to spark, etc.</p>	 <p>Keep the power supply circuit breaker or plug from dirt. Connect the power supply cord to it firmly and correctly, lest an electric shock or a fire break out due to insufficient contact.</p>	 <p>Use correct power supply according to the rating plate. Otherwise, serious faults maybe occur or a fire maybe break out.</p>
 <p>Do not knit, pull or press the power supply cord, lest the power supply cord be broken. An electric shock or fire is probably caused by a broken power supply cord.</p>	 <p>Never insert a stick or similar to the unit. Since the fan rotates at high speed, this may cause an injury.</p>	 <p>It is harmful to your health if the cool air reaches you for a long time. It is advisable to let the air flow be deflected to all the room.</p>
 <p>Turn off the appliance first before cutting off power supply when malfunction occurs.</p>	 <p>Do not repair the appliance by yourself. If this is done incorrectly, it may cause an electric shock, etc.</p>	 <p>Prevent the air flow from reaching the gas burners and stove.</p>
 <p>Do not touch the operation buttons when your hands are wet.</p>	 <p>Pull off the plug to stop it when the operation is abnormal (a peculiar odor is smelled, etc.), or it may cause an electric shock, etc.</p>	 <p>It is the user's responsibility to make the appliance be grounded according to local codes or ordinances by a licenced person.</p>

Parts Names

Front view

► For remote control model

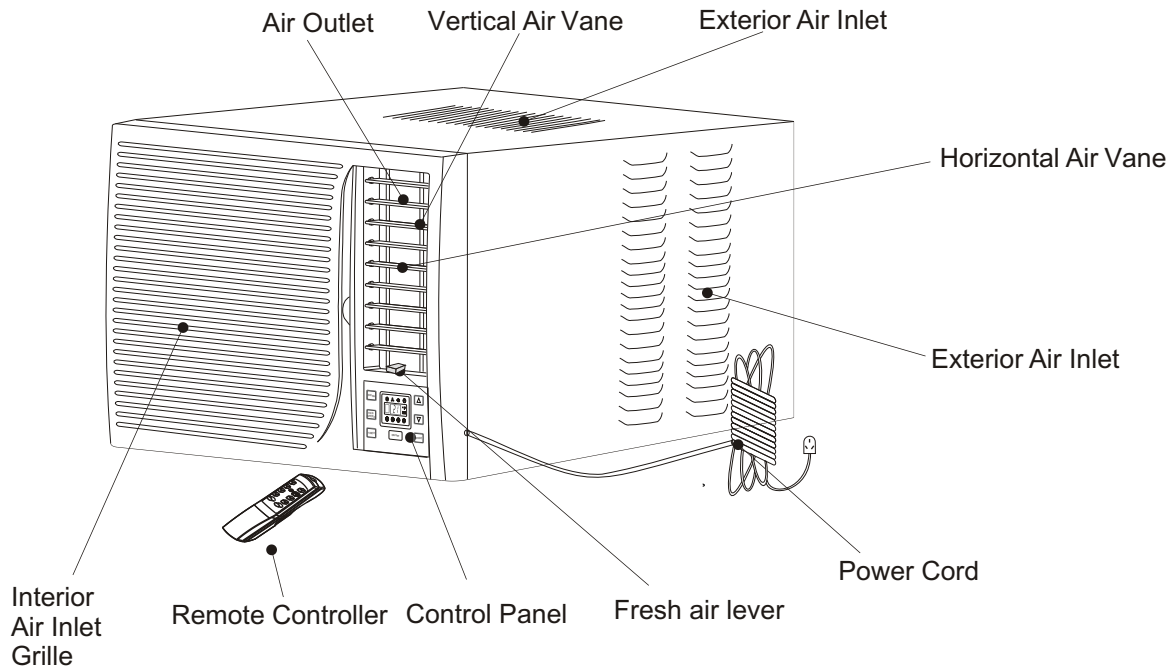
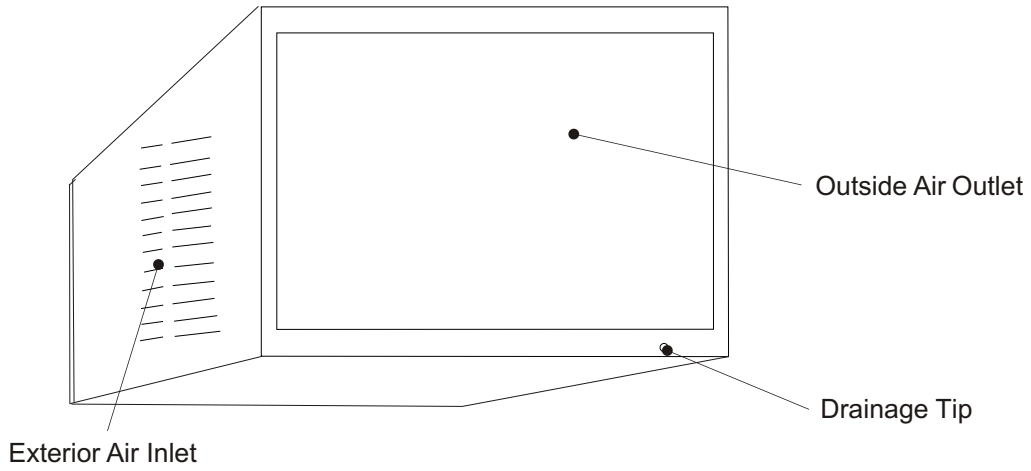

Fig. 1

Note: The figure in this manual are based on the external view of a standard model. Consequently, the shape may differ from that of the air conditioner you have selected.

Parts Name

Back view



Fresh air lever

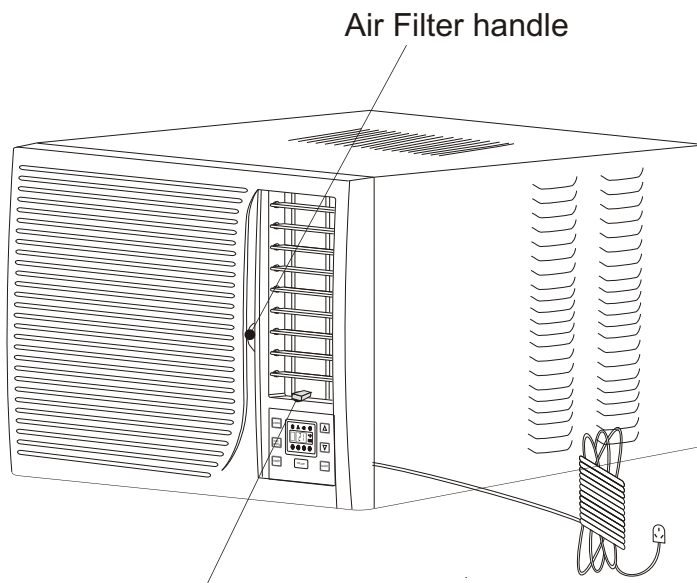

Fresh air lever

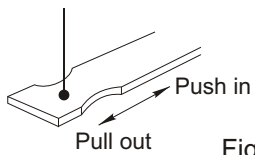

Fresh air lever

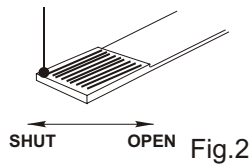

Shut the fresh air door to achieve the best cooling effect and open it to introduce fresh air into the room if the air is foul inside .

Operating Instructions

You can easily operate this air conditioner by pressing the relevant button on the control panel as well as the remote controller.

ON/OFF Button

The air conditioner will start operation or will stop operation when this button is pressed.

MODE Button

Each time the MODE button is pressed, the operation mode is changed in sequence:

COOLING → FAN ONLY → ENERGY SAVING → COOLING

NOTE: After setting a mode, allow 3 minutes before switching to another mode.

FAN SPEED Button

Used to select the fan speed in sequence: auto → low → medium → high.

TIMER Button

Used to set or cancel a timer operation.

When the unit is in operation, you can set the OFF TIMER. When the unit is off, you can set the ON TIMER. Timer setting range is 0 to 24 hours.

If the OFF TIMER is set, the timer LED displays the remaining operating time for only 12 seconds, the display then reverts to displaying the set temperature.

If the ON TIMER is set, the timer LED displays the remaining time to left until turn on.

If you want to cancel the ON TIMER, press the TIMER button again.

▲ ▼ Buttons

Used to set the room temperature in COOLING mode or the time in TIMER mode.

NOTE: The temperature setting range is from 19°C(66°F) to 31°C(88°F).

SWING Button

Used to start or stop the vertical air vanes.

Control Panel

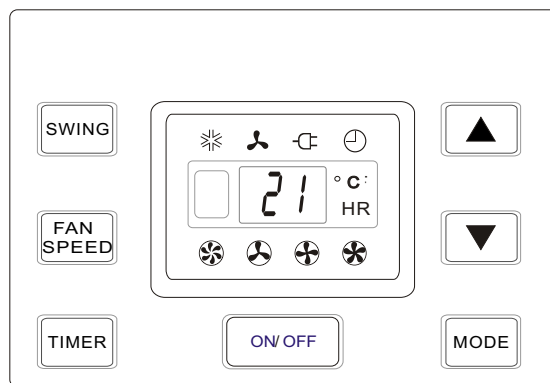

Indication symbols on the LED control panel:

- | | | |
|------------------|---------------|---------------------------------------|
| Auto fan speed | Cooling | Display set temp
Display set timer |
| Low fan speed | Fan only | |
| Medium fan speed | Timer | |
| High fan speed | Energy-saving | |

The above LED symbol lights when the relevant mode is in use.

Operating Instructions

► Remote Controller

The remote controller transmits signals to the system.

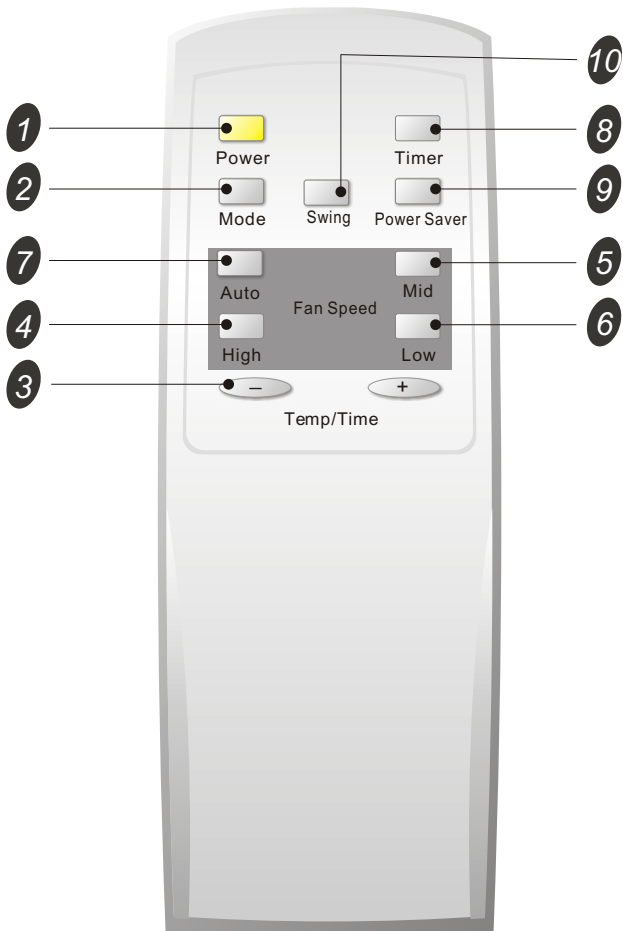

- 1 POWER Button**
The air conditioner will start operation or will stop operation when this button is pressed.
- 2 MODE Button**
Used to select the mode.
- 3 + - Buttons**
Used to set the room temperature in COOLING mode or the time in TIMER mode.
- 4 HIGH Button**
Used to select high fan speed mode.
- 5 MID Button**
Used to select medium fan speed mode.
- 6 LOW Button**
Used to select Low fan speed mode.
- 7 AUTO Button**
Used to select the Auto fan speed mode.
- 8 TIMER Button**
Used to set or cancel a timer operation..
- 9 POWER SAVE Button**
Used to select the Energy-saving mode.
- 10 SWING Button**
Used to start or stop the vertical air vanes.

- ☑ • When changing modes during operation, the unit will not respond instantly. Please wait 3 minutes.
- Wait 3 minutes before restarting the appliance.

Operating Instructions

► Remote Control

How to Insert the Batteries

Remove the battery cover according to the arrow direction. Insert new batteries making sure that the (+) and (-) of the battery are matched correctly. Re attach the cover by sliding it back into position.

Note:
Use 2 LR6 AA(1.5volt) batteries. Do not use rechargeable batteries. Replace batteries with new ones of the same type when the operation becomes erratic. If the replacement is done within 1 minute, the remote control will keep its original presets.

How to Use

To operate the room air conditioner , aim the remote control at the remote sensor. The remote control will operate the air conditioner at a distance of up to 23 feet when pointed at the remote sensor on the main unit.

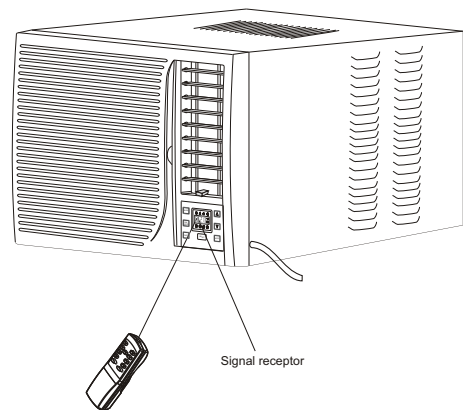
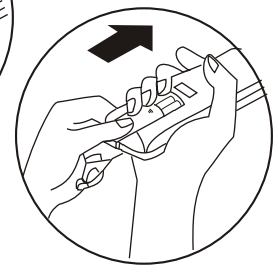
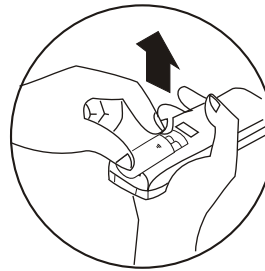
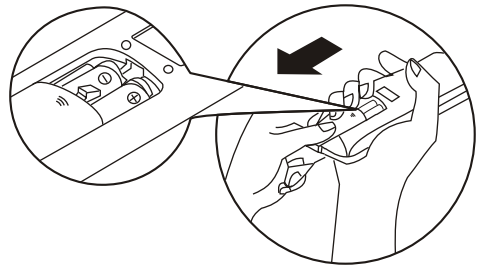

Care and Maintenance

Front panel maintenance

- 1 Unplug from power source

Unplug from power source after switch off the air conditioner.

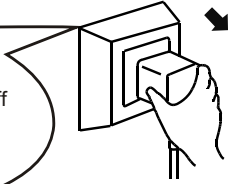

- 2 Wipe with a soft and dry cloth

Use lukewarm water (below 40°C) to clean if the air conditioner is very dirty.



Use a dry and soft cloth to clean it.

- 3 Never use volatile substance such as gasoline or polishing powder to clean the appliance.



Air filter maintenance

- 1 Stop operation and take out air filter.

Take out air filter as shown

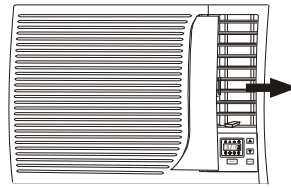

- 2 Clean and reinstall the air filter.

If the dirt is conspicuous, wash it with a solution of detergent in lukewarm water. After cleaning, dry well in shade.



Operation Tips

Operating condition

The protective device maybe trip and stop the appliance in the cases listed below.



COOLING	Outdoor air temperature is over *43°C
	Room temperature is below 21°C

**For Tropical (T3) Climate condition models, the temperature point is 52°C instead of 43°C.*

If the air conditioner runs in COOLING or DRY mode with door or window opened for a long time when relative humidity is above 80%,dew may drip down from the outlet.

Noise pollution

The noise level of air conditioner sounds higher at night than in the daytime.

Please set  (LOW FAN SPEED) or  (FAN ONLY) mode at night in order to decrease noise.

Features of protector

The protective device will work at following cases.

- Restarting the unit at once after operation stops or changing mode during operation, you need to wait 3 minutes.
- Connect to power supply and turn on the unit at once, it may start 20 seconds later.

Caution

① Use proper fuse

- Do not use wire or anything else instead of fuse. Otherwise, air conditioner will be damaged, or cause stock, fire, etc.

② • You need to wait 3 minutes before restarting.

(Note : If you let the appliance on after power cut, the compressor may be burned)

Electrical specifications

1. All wiring must comply with local and national electrical codes and must be installed by a qualified electrician. If you have any questions regarding the following instructions, contact a qualified electrician.
2. Check available power supply and resolve any wiring problems **BEFORE** installing and operating this unit.
3. For your safety and protection. This unit is grounded through the power cord when plugged into a matching wall outlet. **If you are not sure whether your wall outlet is properly grounded, please consult a qualified electrician.**
4. The wall outlet must match the plug on the service cord supplied with the unit.
DO NOT use plug adapters or extension cord.
5. The rating plate on the unit contains electrical and other technical data. The rating plate is located on the cabinet of the unit. Make sure to use correct power supply according to the rating plate of your air conditioner.



Electric Shock Hazard



The air conditioner has a serial plate rating, it must have its own fuse or circuit breaker, and no other device or unit should be operated on be the fuse or circuit breaker.

To avoid the possibility of personal injury, disconnect power to the unit before installing or servicing.

Trouble Shooting

The following cases may not always be a malfunction, please check it before asking for service.

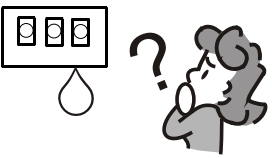
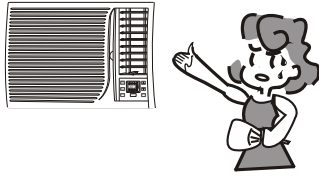
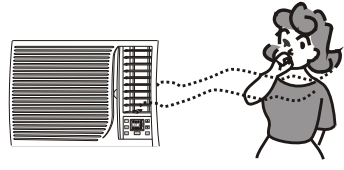
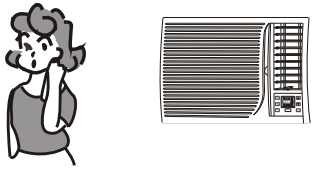
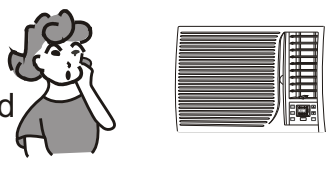
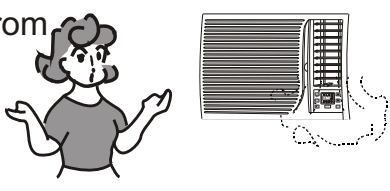
Trouble	Analysis
<p>Does not run</p> 	<ul style="list-style-type: none"> • If the protector trip or fuse is blown. • Please wait for 3 minutes and start again, protector device may be preventing unit to work. • If batteries in the remote controller exhausted. • If the plug is not properly plugged.
<p>Not cool enough</p> 	<ul style="list-style-type: none"> • Is the air filter dirty? • Are the intakes and outlets of the air conditioner blocked? • Is the temperature set properly? • Is the fresh air lever shut off? • Is the door or windows closed?
<p>Peculiar odor</p> 	<ul style="list-style-type: none"> • This odor may come from another source such as furniture, cigarette etc, which is sucked in the unit and blows out with the air.
<p>Sound of flowing water</p> 	<ul style="list-style-type: none"> • Caused by the flow of refrigerant in the air conditioner, not a trouble.
<p>Cracking sound</p> 	<ul style="list-style-type: none"> • The sound may be generated by the expansion or contraction of the front panel due to change of temperature.
<p>Spray mist from the outlet</p> 	<ul style="list-style-type: none"> • Mist appears when the room air becomes very cold because of cool air discharged from indoor unit during COOLING or DRY operation mode.

Installation instructions

Installation accessories

HCBO9

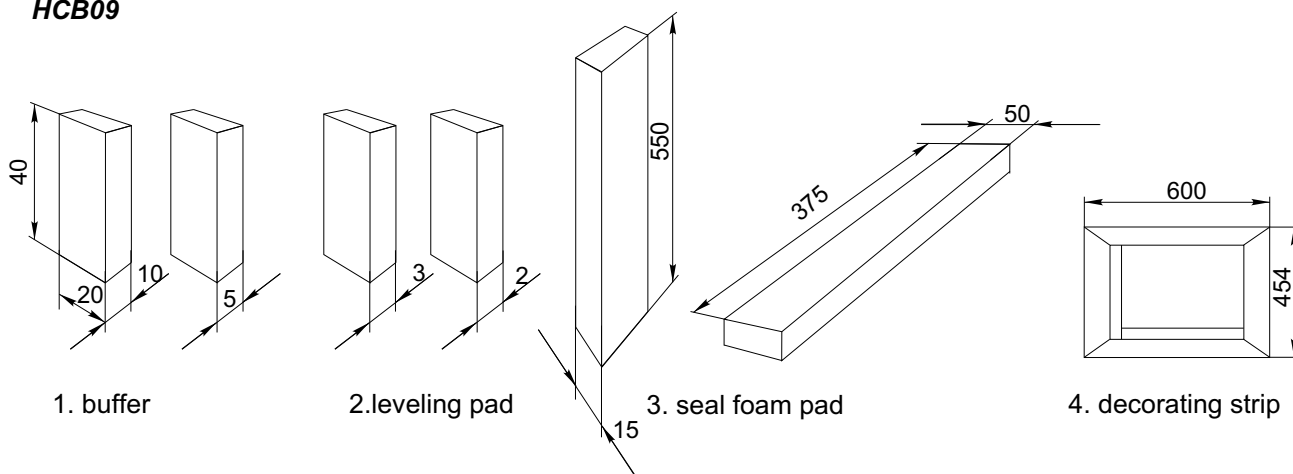

Note: All above accessories are prepared or purchased by user.

HCB12

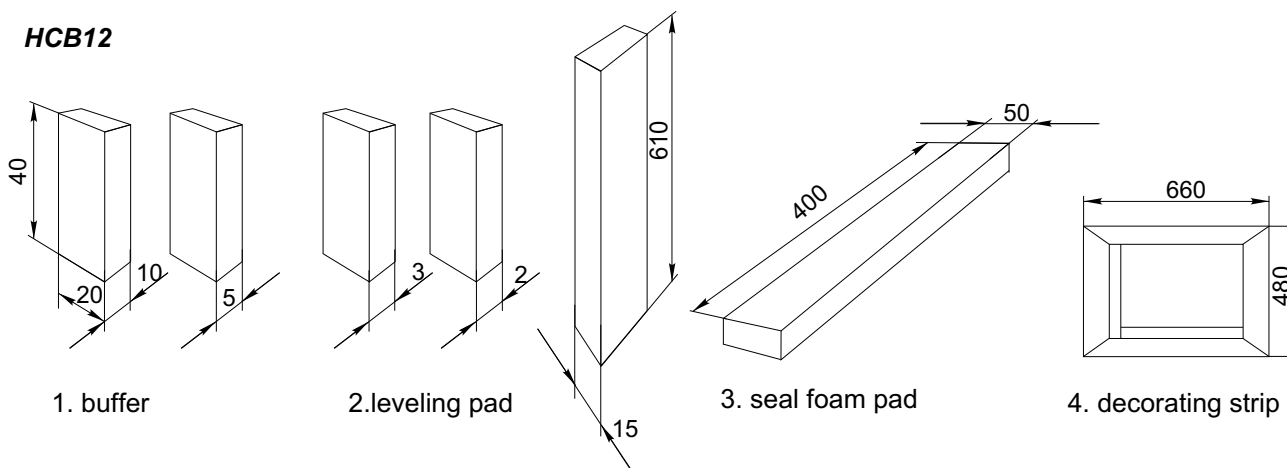

Note: All above accessories are prepared or purchased by user.

Installation requirements

- Leave a space more than 100 cm at the rear of the appliance and ensure the outdoor air intake not be blocked.
- A wooden frame as shown in fig.1 is advisable if the appliance is installed through a window. The installation bracket as shown in fig.2 should not be welded with the window sash.
- The square hole should be smooth enough if the appliance is installed through a wall. A space as shown in fig.3 for outdoor air intake should be prepared if the wall is too thick.
- The metallic installation bracket should be constructed as fig.4.
- All the installation structure should be strong enough.

Installation instructions

HCBO9

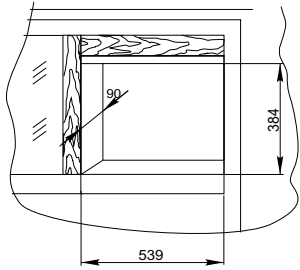

Fig.1

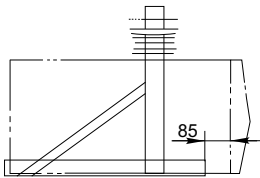

Fig.2

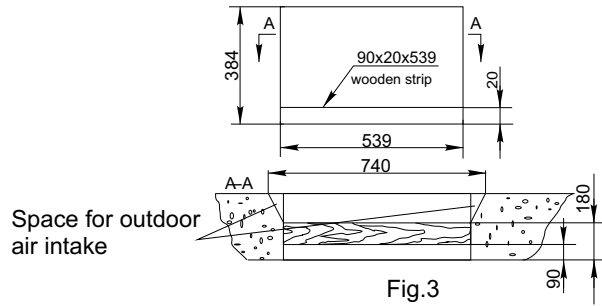

Fig.3

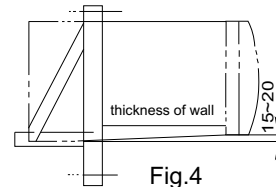

Fig.4

HCBO12

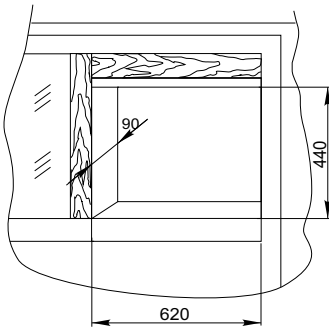

Fig.1

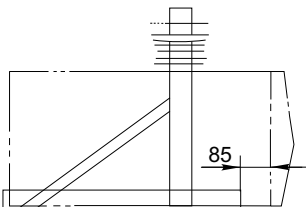

Fig.2

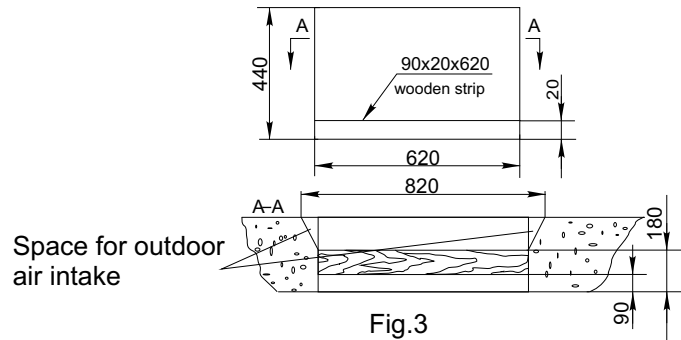

Fig.3

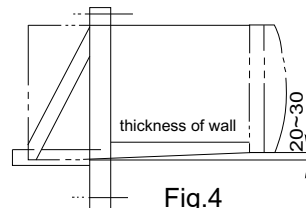

Fig.4

Installation instructions

Installation steps

- Test the appliance by plugging the power supply cord in a correct outlet of power source before installation.
- A clearance of 20 mm is advisable between the appliance cabinet and the wall. Fix the indoor air intake panel with the cabinet by employing two screws which packed in the packing bag as shown in Fig.5.
- Put the buffers on the installation bracket as shown in Fig.6. Adjust the appliance as shown in Fig.4. The leveling pads are employed to tilt the appliance in order that the indoor side is about (15~20) mm higher than the outdoor side for fear the condensate overflow into the room.
- The seal foam pads are employed to prevent outside air from leaking into the room (Fig.7) and the decorating strip is presented for aesthetical appearance as Fig.8.

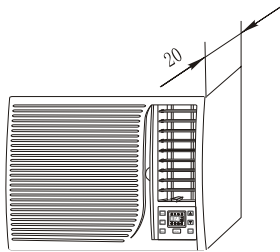

Fig.5

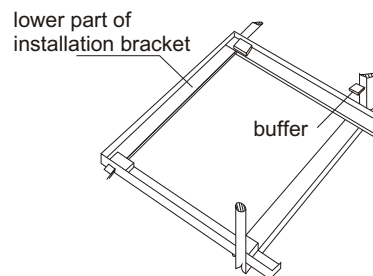

Fig.6

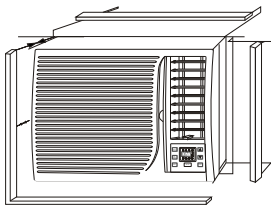

Fig.7

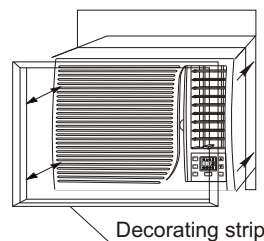

Fig.8

Drainage

Condensate will form during the cooling or dry operation, user can choose drainage or no drainage. Remove the drainage tip and fix the drainage hose when drainage is chosen. On the contrary, the condensate is splashed to cool the condenser so that the cooling capacity and energy conservation is improved with a little high noise when no drainage is chosen.

Fuse and grounding

- A proper time-delay fuse should be employed in the power supply circuit.
- For your personal safety, this air conditioner must be grounded.
- The extension of power supply cord is inadvisable.
- Connect this air conditioner to its own individual wall receptacle to prevent itself and other appliances or household lights from causing a overload that could cause a power outage.

Installation instructions

Installation of the Drain Tube

Fix the drain tube as shown in the figure

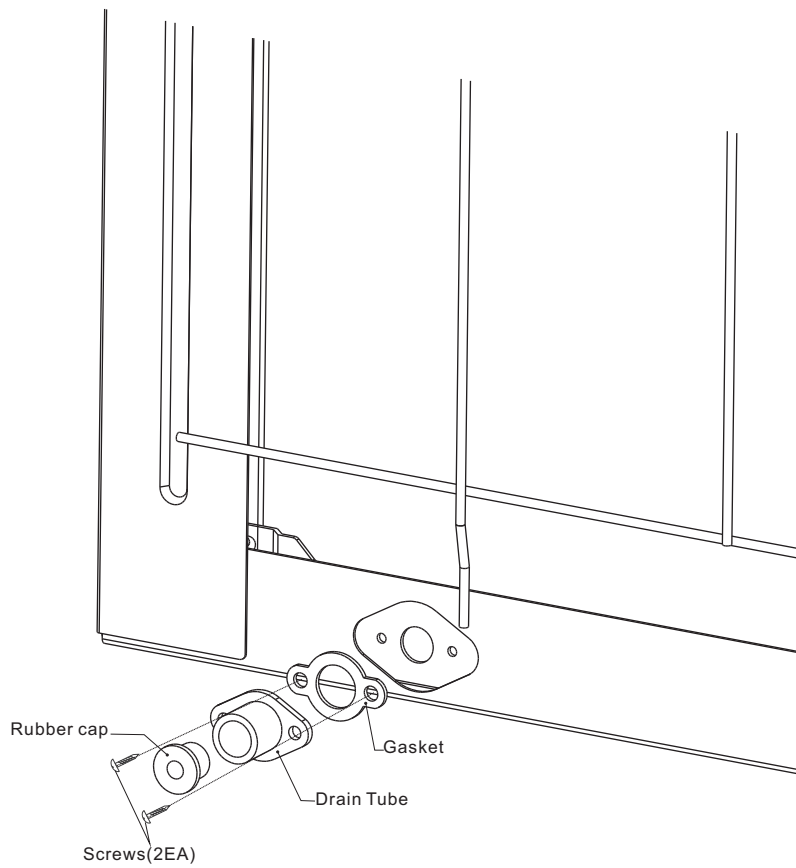

HISENSE WARRANTY

TERMS AND CONDITIONS

1. HISENSE Australia will provide parts and labour to you the Customer as set out herein.
 2. Nothing in the warranty, limits any rights you may have under the trade practices act or any other Commonwealth or State Legislation. Such rights cannot be changed by the conditions in this warranty. Subject to the conditions below this appliance is warranted by Hisense and/or its Agents to be free from defects in materials and workmanship for a period of 60 months from the date of purchase (the "Warranty period")
 3. This warranty: -
 - a. covers products purchased as NEW, manufactured for use in Mainland Australia and Tasmania;
 - b. commences from the date of purchase as listed on the Customers invoice;
 - c. provides for the labour and replacement parts necessary to maintain your product in good operating condition as specified in this warranty however, if repair is needed because of product failure during normal usage, Hisense has the option to repair or replace the defective product or part of the product with a product or part of the product of like kind and quality and a replacement part may be new or reconditioned of like kind and quality and may cost less than the original product purchased and no charges or refunds will be made based on the replacement product cost difference;
 - d. applies only to the original purchaser and cannot be transferred;
 - e. is only applicable when your appliance is used in a domestic environment;
 - f. covers products for commercial purposes for a period of 12 months from the date of purchase.
 4. Product Identification
 - a. Hisense reserves the right to reject claims for any services or work where the Customer requesting such work or services from Hisense and/or its agents cannot produce for verification the serial number and the proof of purchase as per original purchase invoice.
 - b. The warranty will be voided if any Serial Number sticker provided to be placed on the equipment is damaged, modified or removed.
 - c. In the event that a request for repair is made against a warranty where the Serial Number sticker is not attached to the product or the customer cannot produce for verification the original invoice, the repairer will not affect any repairs on the product and the Customer will be charged a service call-out fee.
 5. What is covered by this warranty
 - a. The equipment is covered for faulty workmanship on parts that have failed under normal use which are contained within the product.
 - b. Hisense and/or its Agents will decide if there are any defects in the material and/or workmanship
 - c. This warranty is only applicable for repairs on declared equipment carried out within Mainland Australia and Tasmania
 6. What is not Covered by this warranty (excluded):-
 - a. any damage or failure:
 - i. of equipment due to the product being inadequately serviced to manufacturer's recommendations;
 - ii. resulting from environmental conditions including and not limited to dirt, dust, rodents, insects, rust, corrosion, salt built-up, of any part of the product including its parts; or
 - iii. resulting from excessive use "fair wear and tear";
 - iv. resulting from poor installation including and not limited to positioning and externally fitted equipment such as plumbing and drainage, cabling, antennae or due to Incompatibility of connected equipment;
 - v. to the product caused by overheating as a result of siting or positioning of the equipment, where there is not provision for adequate ventilation or a dust free environment;
 - vi. caused if your appliance has been dismantled, repaired or serviced by any person other than someone authorised by Hisense;
 - vii. to a product or components, caused by power surges or spikes, including and not limited to, mains power and telecommunications connections, or to other unspecified sources, incorrect power current, voltage fluctuation, amperage fluctuation, rust or corrosion;
 - viii. due to a dropped product; collision with another object, use of which is not designed, negligence, accident or deliberate misuse, theft, abuse, vandalism, flood, fire, earthquake, electrical storms or any other act of God or any war related events;
 - ix. due to the introduction of abnormal heat loads to the product;
 - b. costs of attendance and testing where no mechanical or electrical failure is identified;
 - c. initial setup and installation of the product;
 - d. Normal maintenance costs and costs incurred through the installation of items listed as requiring periodic replacement;
 - e. products with removed or altered serial numbers;
 - f. consumables such as but not limited to bulbs/globes, batteries, remote controls;
 - g. removal and reinstallation of an internal component not performed by a factory authorised service centre;
 - h. cosmetic or structural items;
 - i. Any failures due to the interference from or to other products and/or sources;
7. The Warranty Ceases if: -
 - a. The product ceases to carry the original manufacturer's serial number or is sold at an auction;
 - b. The product is rented;
 - c. Damage to the product has occurred as listed in point 6b.
 - d. Failure to pay monies owing on invoices as a result of non warranty work been carried out at the request of the end user as per point 15.
8. Neither Hisense nor its representatives provide loan equipment under the terms of this warranty.
9. Any unauthorised access to the internal hardware of the product will void this warranty.
10. Replacement items are "Like for like" and is not "new for old" and does not indicate in any way that a faulty product will be replaced with a new part or unit. "Like for like" may either be a quality checked refurbished, reconditioned or factory second unit of the same or greater model/size/specifications.
11. If your product is 130 litres capacity or under, and/or if you reside outside of the service coverage area of your nearest authorised service agent, this warranty does not cover the costs of transportation or travel expenses to and from your home.
12. Hisense accepts no liability for items that are lost, damaged, or stolen as a result of freight, transport or storage. If you are required to transport the appliance to an authorised service centre, you must ensure that it is securely packed and insured.
13. On Public Holidays or other periods when regular business and wholesale operations are temporarily ceased, repairer availability and warranty response times may extend beyond the standard response times due to the availability of repairers and parts.
14. Any repair performed on a product under the warranty where no fault can be found, or the item is deemed by Hisense, or an authorised Hisense agent, to be not faulty under this warranty, or the repair or fault is not covered under the warranty, a No Fault Found fee is payable by the warranty holder of a minimum of \$125 inc GST.
15. Any repairs or services required that are outside of the terms and conditions of the warranty can be carried out at the request of the customer or due to site attendance were fault is not covered under warranty as the product not been installed or setup correctly; a credit card may be required prior to the commencement of such services.
16. Extra charges will be payable by the warranty holder should your appliance not be readily accessible without special equipment, such as but not limited to cranes and lifts or should the appliance be installed in a position that service access is blocked and/or repair work is not possible without uninstalling the unit to gain access.

WARRANTY CLAIMS PROCEDURE

Please retain this portion for your records

60 MONTHS IN HOME REPAIR WARRANTY

Hisense Australia will provide its nearest service centre for repairs under warranty. You will need to ensure that you have already called Hisense Warranty Centre and received a JOB NUMBER.

Before making a claim, please make sure that you understand the terms and conditions of the warranty

- Check and ensure the installation of all power cables to the power point are secure and power is turned on, all cables leads and connectors are connected properly and that all switches are turned on and functioning
- Check that there is power at the power point by using a small appliance
- Check that all settings are set according to the instruction manual
- Please keep this certificate in a safe place together with your product receipt. Should you need to make a claim, the responsibility of proof of ownership of the equipment is on you. If a claim is made that is found not to be covered under this warranty, or no faulty hardware components are found, you will be charged at Hisense or Hisense Authorised Service Center's standard service charge plus an administration fee.

PLEASE REFER TO THE TROUBLESHOOTING GUIDE AT THE END OF THIS MANUAL

Service Procedure

Please have your **original invoice, model, and serial number** ready. To receive service, you are required to:

- Call **1800 447 367**. Service claims may be made between **9:00am and 5:00pm AEST** week-days excluding public holidays where a call representative will log your claim for processing.
- You will be provided a **JOB NUMBER**
- Normally under 2 hours of logging and receiving your proof of purchase for your claim, an Authorised Service Agent will contact you to proceed with claim.

WARRANTY REGISTRATION

In order to register your warranty, please fill out and return with a copy of your invoice to:

**Hisense Warranty Registration
PO BOX 2268 Seaford Victoria 3198 Australia**

Congratulations on your purchase, This Document sets out terms and conditions of your product warranty. Please Keep it with your proof of purchase information in a safe place for future reference should you require service to your product.

The Undersigned hereby acknowledges receipt of the Hisense warranty service provided. I have read and understand the conditions and terms of the warranty in its entirety.

NAME OF PURCHASER _____

SERIAL NUMBER _____

ADDRESS _____

STORE PURCHASED FROM _____

CITY _____ STATE _____ POSTCODE _____

CITY _____ STATE _____ POSTCODE _____

PHONE (____) _____

INVOICE NO. _____

MOBILE (____) _____

MODEL NO. _____

FAX (____) _____

DATE OF PURCHASE ____/____/____

SIGNATURE _____