

t28 series

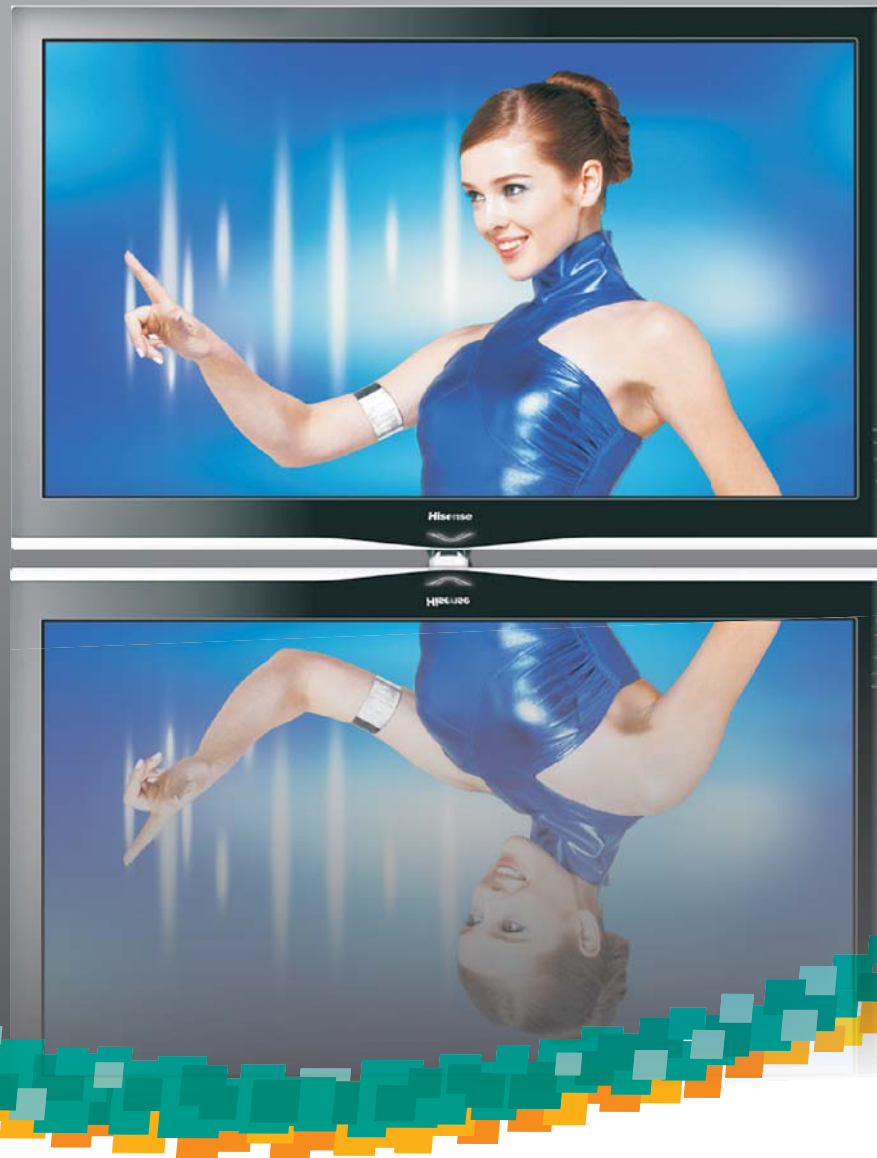

Hisense[®]

User's manual

Please read this manual carefully before operating your TV set and retain it for further reference.

Model Number: **HL19T28L** **HL22T28PL**

Part Number: **ES-G100101**

[Http://www.hisense.com.au](http://www.hisense.com.au)

HISENSE WARRANTY

TERMS AND CONDITIONS

1. HISENSE Australia will provide parts and labour to you the Customer as set out herein.
2. Nothing in the warranty, limits any rights you may have under the trade practices act or any other Commonwealth or State Legislation. Such rights cannot be changed by the conditions in this warranty. Subject to the conditions below this appliance is warranted by Hisense and/or its Agents to be free from defects in materials and workmanship for a period of 12 months on DVD integrated models and 36 months on non combination models from the date of purchase (the "Warranty period")
3. This warranty: -
 - a. covers products purchased as NEW, manufactured for use in Mainland Australia and Tasmania;
 - b. commences from the date of purchase as listed on the Customers invoice;
 - c. provides for the labour and replacement parts necessary to maintain your product in good operating condition as specified in this warranty however, if repair is needed because of product failure during normal usage, Hisense has the option to repair or replace the defective product or part of the product with a product or part of the product of like kind and quality and a replacement part may be new or reconditioned of like kind and quality and may cost less than the original product purchased and no charges or refunds will be made based on the replacement product cost difference;
 - d. applies only to the original purchaser and cannot be transferred;
 - e. is only applicable when your appliance is used in a domestic environment;
4. Product Identification
 - a. Hisense reserves the right to reject claims for any services or work where the Customer requesting such work or services from Hisense and/or its agents cannot produce for verification the serial number and the proof of purchase as per original purchase invoice.
 - b. The warranty will be voided if any Serial Number sticker provided to be placed on the equipment is damaged, modified or removed.
 - c. In the event that a request for repair is made against a warranty where the Serial Number sticker is not attached to the product or the customer cannot produce for verification the original invoice, the repairer will not affect any repairs on the product and the Customer will be charged a service call-out fee.
5. What is covered by this warranty
 - a. The equipment is covered for faulty workmanship on parts that have failed under normal use which are contained within the product.
 - b. Hisense and/or its Agents will decide if there are any defects in the material and/or workmanship
 - c. This warranty is only applicable for repairs on declared equipment carried out within Mainland Australia and Tasmania
6. What is not Covered by this warranty (excluded):-
 - a. any damage or failure:
 - i. of equipment due to the product being inadequately serviced to manufacturer's recommendations;
 - ii. resulting from environmental conditions including and not limited to dirt, dust, rodents, insects, rust, corrosion, salt built-up, of any part of the product including its parts; or
 - iii. resulting from excessive use "fair wear and tear";
 - iv. resulting from poor installation including and not limited to positioning and externally fitted equipment such as plumbing and drainage, cabling, antennae or due to Incompatibility of connected equipment;
 - v. to the product caused by overheating as a result of siting or positioning of the equipment, where there is not provision for adequate ventilation or a dust free environment;
 - vi. caused if your appliance has been dismantled, repaired or serviced by any person other than someone authorised by Hisense;
 - vii. to a product or components, caused by power surges or spikes, including and not limited to, mains power and telecommunications connections, or to other unspecified sources, incorrect power current, voltage fluctuation, amperage fluctuation, rust or corrosion;
 - viii. due to a dropped product; collision with another object, use of which is not designed, negligence, accident or deliberate misuse, theft, abuse, vandalism, flood, fire, earthquake, electrical storms or any other act of God or any war related events;
 - b. costs of attendance and testing where no mechanical or electrical failure is identified;
 - c. initial setup and installation of the product;
 - d. Normal maintenance costs and costs incurred through the installation of items listed as requiring periodic replacement;
 - e. products with removed or altered serial numbers;
 - f. consumables such as but not limited to bulbs/globes, batteries, remote controls;
 - g. removal and reinstallation of an internal component not performed by a factory authorised service centre;
 - h. cosmetic or structural items;
 - i. Any failures due to the interference from or to other products and/or sources;
 - j. Inability of the product to read or output damaged or copied media;
7. The Warranty Ceases if: -
 - a. The product ceases to carry the original manufacturer's serial number or is sold at an auction;
 - b. The product is rented;
 - c. Damage to the product has occurred as listed in point 6b.
8. Neither Hisense nor its representatives provide loan equipment under the terms of this warranty.
9. Any unauthorised access to the internal hardware of the product will void this warranty.
10. Replacement items are "Like for like" and is not "new for old" and does not indicate in any way that a faulty product will be replaced with a new part or unit.
11. If you reside outside of the service coverage area of your nearest authorised service agent, this warranty does not cover the costs of transportation or travel expenses to and from your home.
12. Hisense accepts no liability for items that are lost, damaged, or stolen as a result of freight, transport or storage. If you are required to transport the appliance to an authorised service centre, you must ensure that it is securely packed and insured.
13. On Public Holidays or other periods when regular business and wholesale operations are temporarily ceased, repairer availability and warranty response times may extend beyond the standard response times due to the availability of repairers and parts.
14. Special Conditions relating to Plasma TV's, LCD TV's, Panels, Projection Television and Projections Equipment
 - a. All LCD and Plasma Panels exhibit some bright, dark or partially lit pixels, a normal limitation of these technologies, and the manufacturing processes involved and are usually not noticeable when viewing normal screen images and defective pixels are not a warranty issue unless they exceed the manufacturer's specifications for pixel defects. Where there are no manufacturer specifications, Hisense covers the screen provided for 12 or more pixels that are failing to display
 - b. Image retention or burn-in can be a problem for all phosphor based displays. In extreme cases, permanent phosphor burn can occur if still/repetitive images are left on the screen for extended periods of time. Such damage to the screen is not covered by the warranty. Please ensure that the precautions in any documentation supplied with your product are followed in order to avoid permanent damage to your display.
 - c. Where a product is positioned higher than 1.2m from the lowest mount point, is wall/ceiling mounted or where aftermarket mounts and/or stands are used, or where the unit has not been installed by a professional installer, an extra service charge will apply to unfix and refix this product.
15. Any repair performed on a product under the warranty where no fault can be found, or the item is deemed by Hisense, or an authorised Hisense agent, to be not faulty under this warranty, or the repair or fault is not covered under the warranty, a No Fault Found fee is payable by the warranty holder of a minimum of \$125 inc GST.
16. Any repairs or services required that are outside of the terms and conditions of the warranty can be carried out at the request of the customer or due to site attendance were fault is not covered under warranty as the product not been installed or setup correctly; a credit card may be required prior to the commencement of such services.

WARRANTY CLAIMS PROCEDURE

Please retain this portion for your records

36 MONTHS IN HOME REPLACEMENT WARRANTY*

Hisense Australia will provide its nearest service centre for repairs under warranty. You will need to ensure that you have already called Hisense Warranty Centre and received a JOB NUMBER.

**Non Combination Models only*

12 MONTHS IN HOME REPLACEMENT LCD WARRANTY*

Hisense Australia will provide its nearest service centre for repairs or replacement under warranty. You will need to ensure that you have already called Hisense Warranty Centre and have received a JOB NUMBER.

** Excludes DVD Drive related faults which Hisense Australia provides a separate service stated below*

12 MONTHS COURIER HOTSWAP DVD DRIVE WARRANTY*

Hisense Australia will provide a replacement removable DVD Drive, should you be experiencing DVD related faults, via courier which can easily be replaced by following the instructions for replacement within this manual.

**The faulty DVD drive must be returned to Hisense Australia or you may be liable for the cost of the part and freight*

Before making a claim, please make sure that you understand the terms and conditions of the warranty

- Check and ensure the installation of all power cables to the power point are secure and power is turned on, all cables leads and connectors are connected properly and that all switches are turned on and functioning
- Check that there is power at the power point by using a small appliance
- Check that all settings are set according to the instruction manual
- Please keep this certificate in a safe place together with your product receipt. Should you need to make a claim, the responsibility of proof of ownership of the equipment is on you. If a claim is made that is found not to be covered under this warranty, or no faulty hardware components are found, you will be charged at Hisense or Hisense Authorised Service Center's standard service charge plus an administration fee.

PLEASE REFER TO THE TROUBLESHOOTING GUIDE AT THE END OF THIS MANUAL

Service Procedure

Please have your **original invoice, model, and serial number** ready. To receive service, you are required to:

- Call **1800 447 367**. Service claims may be made between **9:00am and 5:00pm AEST** weekdays excluding public holidays where a call representative will log your claim for processing.
- You will be provided a **JOB NUMBER**
- You are required to fax or email your original invoice prior to a replacement been shipped
- Normally under 2 hours of logging and receiving your proof of purchase for your claim, an Authorised Service Agent will contact you to proceed with claim.

WARRANTY REGISTRATION

In order to register your warranty, please fill out and return with a copy of your invoice to:

**Hisense Warranty Registration
PO BOX 2268 Seaford Victoria 3198 Australia**

Congratulations on your purchase, This Document sets out terms and conditions of your product warranty. Please Keep it with your proof of purchase information in a safe place for future reference should you require service to your product.

The Undersigned hereby acknowledges receipt of the Hisense warranty service provided. I have read and understand the conditions and terms of the warranty in its entirety.

NAME OF PURCHASER _____

SERIAL NUMBER _____

ADDRESS _____

STORE PURCHASED FROM _____

CITY _____ STATE _____ POSTCODE _____

CITY _____ STATE _____ POSTCODE _____

PHONE (____) _____

INVOICE NO. _____

MOBILE (____) _____

MODEL NO. _____

FAX (____) _____

DATE OF PURCHASE ____/____/____

SIGNATURE _____

This page has been left blank intentionally.

Table of Contents



Table of Contents

Hisense Declaration.....	5
Important safety precautions.....	6
Safeguards.....	6
Setting Up.....	9
Accessories.....	9
Installing the Stand.....	9
TV Front.....	10
TV Rear.....	11
Rear TV Connectors.....	12
Connection Instructions.....	13
Using the Remote Control.....	15
Installing batteries.....	15
The Remote Control Panel.....	16
Quick starts.....	17
Changing the TV Settings.....	19
Using the Channel Menu.....	19
Using the Picture Menu.....	21
Using the Sound Menu.....	22
Using the Function Menu.....	23
Using the Lock Menu.....	24
Using the Screen Menu.....	25
PC Setting	26
Using the DMP Menu.....	27
Appendix.....	29
Trouble shooting.....	29
Specifications.....	30



Any content and service accessed through this device, while only intended for individual non-commercial use, shall be the property of the applicable third party and subject to protection by regulations and laws on copyright, patent, trademark and other intellectual property rights. No part of such content and service may be modified, duplicated, published, uploaded, distributed, translated, marketed, or used to make and distribute products derived from it without the prior permission of the content owner or service provider.

You acknowledge and agree explicitly that you will solely bear the risk associated with the use of this device, and further you will solely bear any risk related to satisfactory quality, performance and accuracy for any content and service accessed through this device. To the maximum extent permitted by applicable law, this device and any third party's content and service is provided as it is without any guarantee, express or implied.



Hisense hereby declare explicitly that Hisense shall not be held liable for any guarantee and conditions, express or implied, related to this device and any content and service, including but not limit to warranty on marketability, satisfactory quality, fitness for a particular purpose, accuracy, quiet use and non-violation of any third party's rights; to the maximum extent permitted by applicable law, Hisense gives no guarantee on the accuracy, validity, timeliness, legitimacy and completeness of any content or service provided through this device, or the fitness of such device, content or service for your particular requirement, or the protection from interruption and error during operation of such device, content or service; to the maximum extent permitted by applicable law, in any case, including fault or neglect, Hisense shall not be held liable for legal actions or indemnity obligation arising from any consequence as a result of or related to any information loaded in this device or use of such device, content or service by you or any third party .



Any content and service provided as it is together with this device shall be the property of the applicable third party, therefore Hisense gives no declaration or warranty on modification, suspension, cancellation, termination or abortion thereof, and shall not be held liable for legal actions or indemnity obligation arising thereof.

Hisense reserves the rights to restrict the use or access of certain content or service. As the content and service are transmitted through third party's network and transmission facilities, Hisense undertakes no customer service thereof or the obligation for such customer service.



Safeguards

	This symbol alerts user about the presence of a dangerous voltage not isolated inside the product which can be sufficiently powerful to constitute a risk of electrocution.
	This symbol alerts user about the presence of important operating instructions and maintenance in the document enclosed in the package.

	ATTENTION RISK OF SHOCK ELECTRIC	
<p>Do not open the back cover In no case the user is allowed to operate inside the TV set. Only a qualified technician is entitled to operate.</p>		

Disposal of Used Electrical & Electronic Equipment



Packaging and electrical goods should be recycled appropriately, and not treated as household waste. Please dispose of this equipment at your applicable collection point for the recycling of electrical & electronic equipment waste. By ensuring the correct disposal of this product, you will help prevent potentially hazardous to the environment and to human health, which could otherwise be caused by unsuitable waste handling of this product. The recycling of materials will help conserve natural resources. Please do not therefore dispose of your old electrical and electronic equipment with your household waste. For more detailed information about recycling of this product, please contact your local city office, your household waste disposal service or the shop where you purchased the product.

Important safety precautions



Safeguards

Please read the following safeguards for your TV and retain for future reference. Always follow all warnings and instructions marked on the television.

1. A note about safety and operating instructions
Read and follow all safety and operating instructions, and retain them safely for future reference.
2. Heed Warnings
Adhere to all warnings on the appliance and in the operating instructions.
3. Cleaning
Unplug the TV from the wall outlet before cleaning. Do not use liquid, abrasive, or aerosol cleaners. Cleaners can permanently damage the cabinet and screen. Use a lightly dampened cloth for cleaning.
4. Wall Bracket
Wall brackets are not supplied with this product. After market brackets may be available to purchase locally. Please refer to the specification page for dimensions.
5. Water and Moisture
Avoid dripping or splashing of liquids onto the product. Objects filled with liquids, such as vases, should not be placed on the product.
6. Setting
Do not place this TV on an unstable cart, stand or table. Placing the TV on an unstable base can cause the TV to fall, resulting in serious personal injuries as well as damage to the TV. Use only a cart, stand, bracket or table recommended by the manufacturer or salesperson.
7. Ventilation
Slots and openings in the cabinet are provided for ventilation, to ensure reliable operation of the TV and to protect it from overheating. Do not cover the ventilation openings in the cabinet and never place the set in a confined space such as built-in cabinet unless proper ventilation is provided. Leave a minimum 10cm gap all around the unit.
8. Power Source
This TV should be operated only from the type of power source indicated on the marking label. If you are not sure of the type of power supplied to your home, consult your appliance dealer or local power company.
9. Grounding or Polarization
This TV is equipped with a polarized alternating current line plug. This plug will fit into the power outlet only one way. This is a safety feature. If you are unable to insert the plug fully into the outlet, try reversing the plug. If the plug should still fail to fit, contact your electrician to replace your obsolete outlet. Do not defeat the safety purpose of the polarized plug. A warning that an apparatus with CLASS I construction must be connected to a MAINS socket outlet with a protective earthing connection.
10. Power-Cord Protection
Power- supply cords should be routed so that they are not likely to be walked on or pinched by items placed upon or against them, paying particular attention to cords at plug, wall outlets, and the point where they exit from the TV. MAIN plug is used as the disconnect device, the disconnect device shall remain readily operable.
11. Lightning
For added protection for this TV during a lightning storm, or when it is left unattended and unused for long periods of time, unplug it from the wall outlet and disconnect the antenna or cable system. This will prevent damage to the TV due to lightning or power-line surge.

Important safety precautions



Safeguards

12. Power Lines

An outside antenna system should not be located in the vicinity of overhead power lines or other electric light or power circuits, or where it can fall into such power lines or circuits. Where installing an outside antenna system, extreme care should be taken to keep from touching such power lines or circuits as contact with them might be fatal.

13. Overloading

Do not overload wall outlets and extension cords as this can result in a risk of fire or electric shock.

14. Object and Liquid Entry

Never push objects of any kind into this TV through openings as they may touch dangerous voltage points or short-out parts that could result in fire or electric shock. Never spill liquid of any kind on or into the TV.

15. Outdoor Antenna Grounding

If an outside antenna or cable system is connected to the TV, be sure the antenna or cable system is grounded so as to provide some protection against voltage surges and built-up static charges. Section 810 of the National Electric Code, ANSI/NFPA No. 70-1984, provides information with respect to proper grounding of the mast and supporting structure, grounding of the lead in wire to an antenna discharge unit, connection to grounding electrodes, and requirements for the grounding electrode.

16. Servicing

Do not attempt to service this TV yourself as opening or removing covers may expose you to dangerous voltage or other hazards. Refer all servicing to qualified service personnel.

17. Damage Requiring Service

Unplug the TV from the wall outlet and refer servicing to qualified service personnel under the following conditions:

- (a) When the power - supply cord or plug is damaged.
- (b) If liquid has been spilled, or objects have fallen into the TV.
- (c) If the TV has been exposed to rain or water.
- (d) If the TV does not operate normally by following the operating instructions. Adjust only those controls that are covered by the operating instructions as an improper adjustment of other controls may result in damage and will often require extensive work by a qualified technician to restore the TV to its normal operation.
- (e) If the TV has been dropped or the cabinet has been damaged.
- (f) When the TV exhibits a distinct change in performance - this indicates a need for service.

18. Replacement Parts

When replacement parts are required, be sure the service technician has used replacement parts specified by the manufacturer or have the same characteristics as the original part. Unauthorized substitutions may result in fire, electric shock or other hazards.

19. Safety Check

Upon completion of any service or repair to the TV, ask the service technician to perform safety checks to determine that the TV is in safe operating condition.

20. Heat

The product should be situated away from heat sources such as radiators, heat registers, stoves, or other products (including amplifiers) that produce heat.



Accessories list

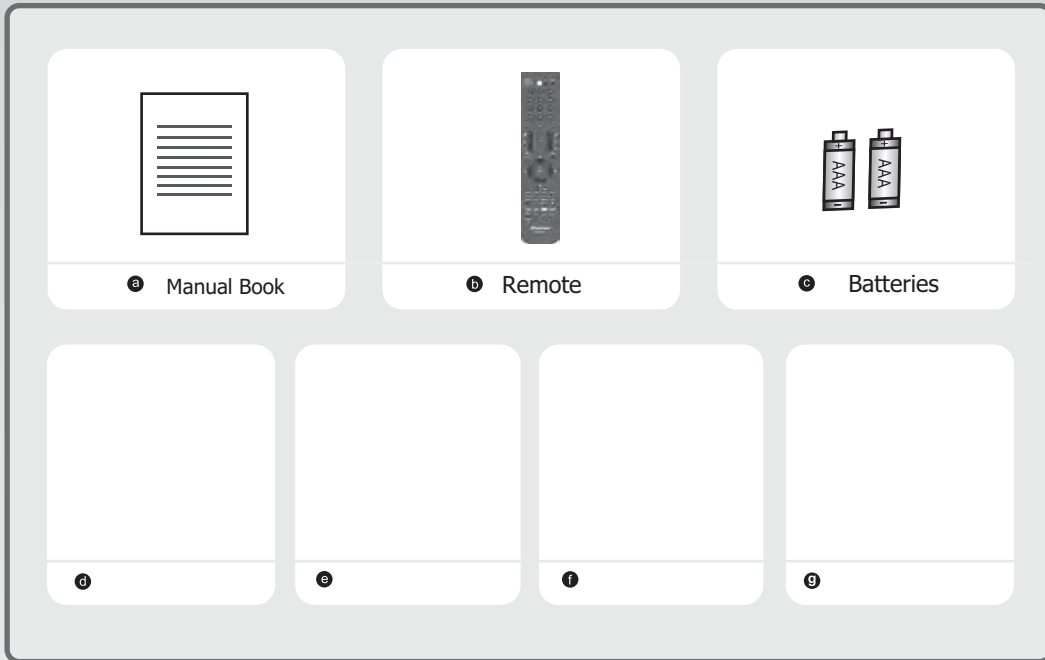

Installing the Stand

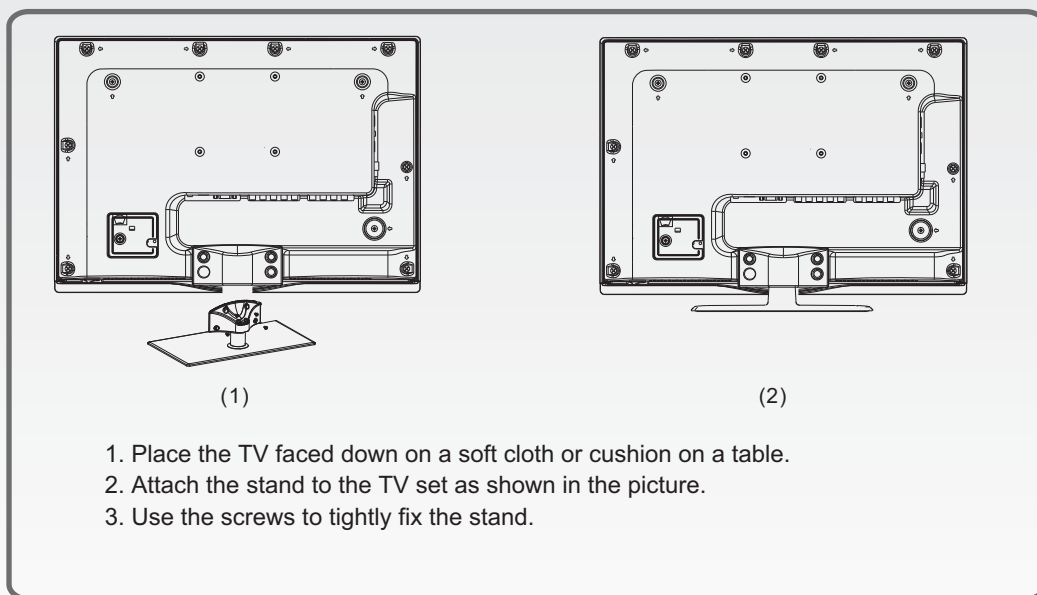

Setting Up



TV Front

TV Front

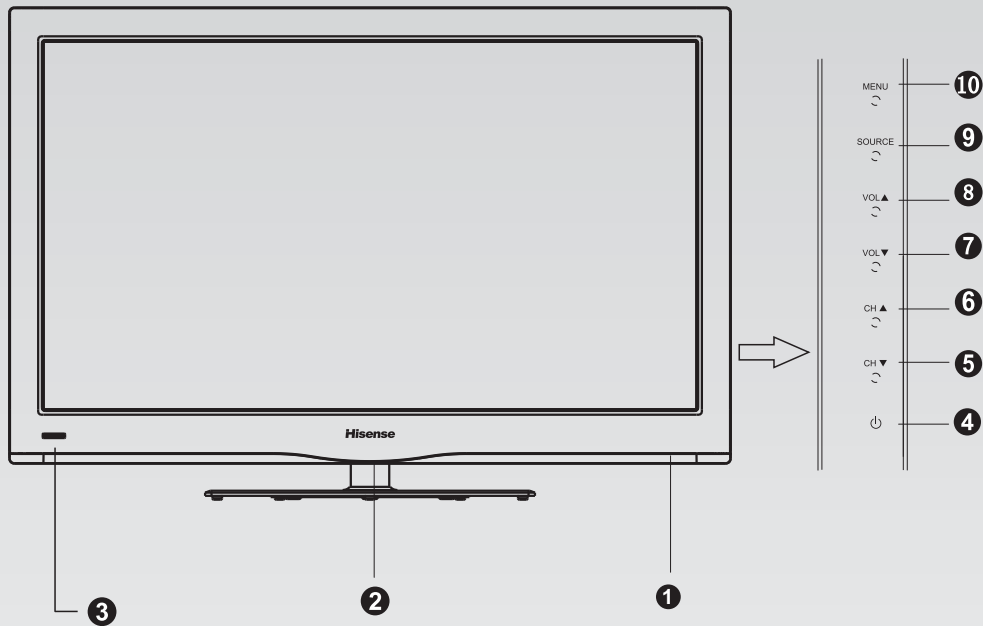

No.	Component	Component Description
1	POWER Button	Press to turn on/off TV.
2	POWER Indicator	Bright light indicates standby mode. The light will flicker after pressing the power standby button, and disappear until the TV is on. You can also control it by yourself.
3	Remote sensor	Receiving signals from the remote emitter. Do not block.
4	POWER Switch	Press to turn the standby ON or OFF.
5	CH▼	Press to go to the previous channel.
6	CH▲	Press to go to the next channel.
7	VOL▼	Press to decrease the volume.
8	VOL▲	Press to increase the volume.
9	SOURCE button	Press to select the signal source for your TV.
10	MENU button	Press to activate the on-screen display (OSD).

Setting Up



TV Rear

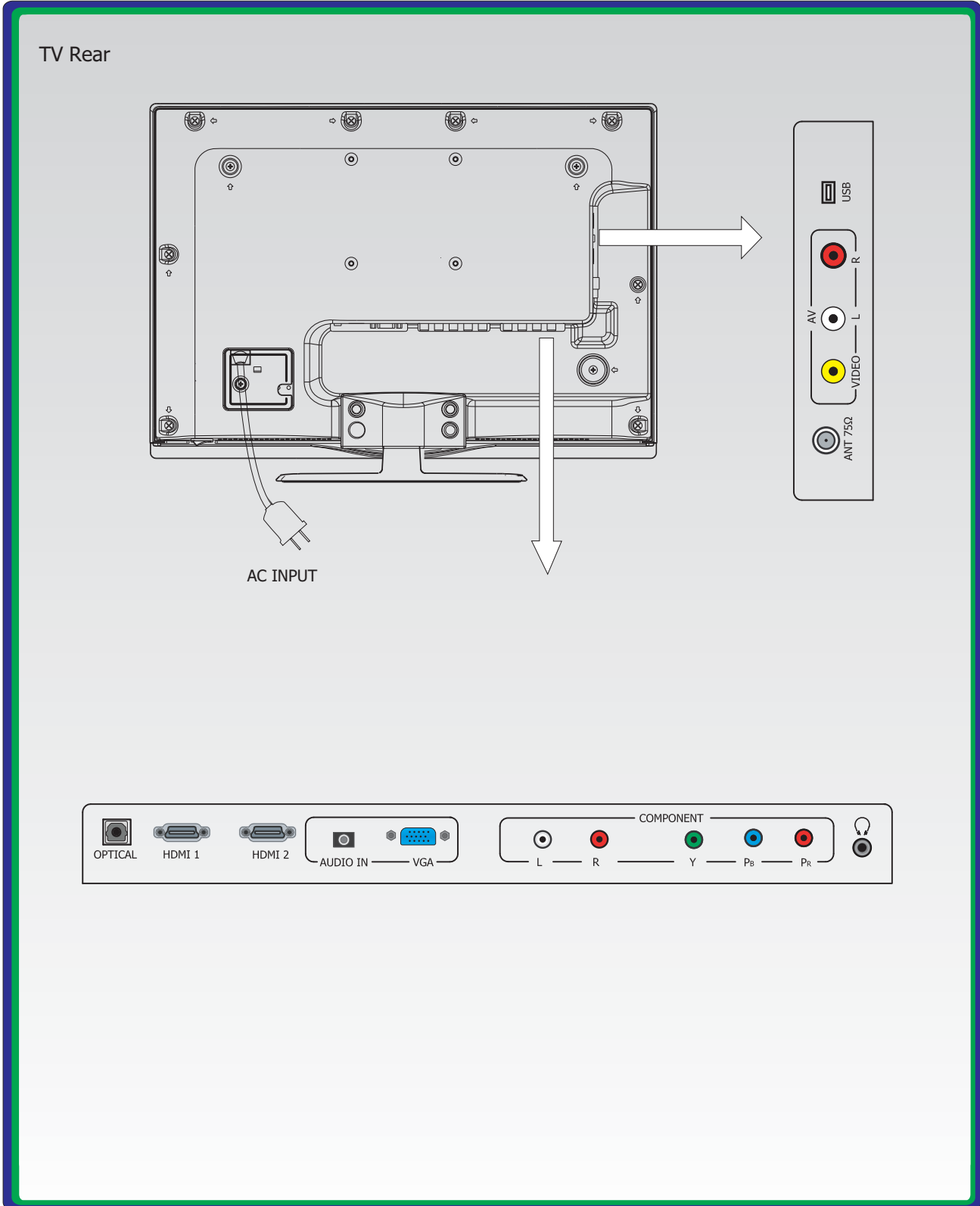

Setting Up



Rear TV Connectors

	TV	Connectors	Cables	Brief Description
1	ANT 75Ω			Connect an outdoor VHF/UHF antenna
2	Video(AV) Input	Video		Connect a composite video cable and left-right audio cables from optical equipment.
		L		
		R		
3	Component Input (COMP)	Y		Connect component video cables and left-right audio cables from optical equipment.
		PB		
		PR		
		L		
		R		
4	HDMI			Connect a HDMI High Definition Multimedia cable from optical equipment.
5	VGA Input	VGA		Connect a VGA cable from your PC to use the TV as a monitor. Connect an audio cable from the optical PC audio out.
		PC AUDIO		
6	OPTICAL			Connect an optical cable to an external digital audio system
7	USB			USB : Connect a USB device for browsing photos,music, movies and recording live TV.
8	HEADPHONE			HEADPHONE:Connect Headphone's for audio out of the TV.



Connection Instructions

■ Connecting an Aerial (For analogue and Digital signals)

To view television channels correctly, a signal must be received by the set from the following source:

- An outdoor VHF/UHF antenna

■ Connecting External A/V Devices

- Connect a Video RCA or S-VIDEO cable to an appropriate external A/V device such as a VCR, DVD or Camcorder.
- Connect RCA audio cables to "R -AUDIO - L" and Video/S-Video on the rear of your set and the other ends to corresponding audio and Video/S-Video out connectors on the A/V device.

■ Connecting Component Devices (DVD/PVR)

-Connect Component video and audio cables to Component inputs ("PR/CR", "PB/CB", "Y") on the rear of your set and the other ends to corresponding component video out connectors on the PVR or DVD.

-The Y, PB/CB and PR/CR" connectors on your component devices (PVR or DVD) are sometimes labeled Y, B-Y and R-Y or Y, CB and CR. (Colours for inputs and cables must correspond on both devices.)

NOTE: Some devices such as a PVR or DVD player require a 'Component/YPBPR'signal to be set to output in the devices settings - please consult your device user manual for instructions.

■ Connecting HDMI

-Supports digital connections between HDMI - enabled AV devices such as (PVRs, DVD, BluRay, HDDVD, AV receivers and digital devices.).

-No sound connection is needed for HDMI to HDMI connection.

NOTE: Some devices such as a PVR or DVD players require a HDMI signal to be set to output in the device's settings.

- Please consult your device user manual for instructions.

What is HDMI?

- HDMI, or high-definition multimedia interface, is a next-generation interface that enables the transmission of digital audio and video signals using a single cable without compression.

- "Multimedia interface" is a more accurate name for it especially because it allows multiple channels of digital audio (5.1 channels). The difference between HDMI and DVI is that the HDMI device is smaller in size, has the HDCP (High Bandwidth Digital Copy Protection) coding feature installed, and supports multi - channel digital audio.

-Use the HDMI terminal for HDMI connection to a compatible device. If your external device has DVI only, you should use a DVI-to-HDMI cable (or adapter) for the connection, and the "R -AUDIO - L" terminal on DVI for sound output.

■ Connecting a Computer

-Connect the D- Sub cable to "VGA" on the rear of your set and the other end to the Video Card of your computer.

-Connect the stereo audio cable to "VGA AUDIO" on the rear of your set and the other end to "Audio Out" of the sound card on your computer.

-Primarily this unit is intended for use as an LCD TV. If using as a monitor, and compatibility is a problem. Please contact the manufacturer of the PC Video/Graphic's card for further support. Perfect compatibility is not warranted.



▶ Connection Instructions

■ Connecting AUDIO

-Connect RCA audio cables to "R -AUDIO - L" on the rear of your set and the other ends to corresponding audio in connectors on the Amplifier or DVD Home Theater.

■ Connecting USB data Devices

-Connect a USB device for browsing photos, playing AVI files and reading text files also used for servicing

■ Optical Audio

Connect an optical audio device to this jack (Toslink optical cable is needed).

■ Headphones

- Headphones can be connected to the headphone output on the side of your set. (While the headphone is connected, the sound from the built-in speakers will be disabled.)



Installing batteries

Installing the remote control batteries

1. Slide open the battery cover on the back of the remote control.
2. Install two AAA size(1.5V) batteries. Match the “+” and “-” signs on the batteries to the signs on the battery compartment.



3. Close the battery cover.

Note:

1. Dispose of your batteries in a designated disposal area. Do not throw the batteries into fire.
2. Do not mix battery types or combine used batteries with new ones.
3. Remove depleted batteries immediately to prevent battery acid from leaking into the battery compartment.
4. If you do not intend to use the remote control for a long time, remove the batteries.
5. The effective range of remote control is suggested in the figure below.

Remote control range

1. The remote control distance: 8 meters in front of the TV set.
2. The remote control angle: taking the television infrared light receiver window as an apex, 6 meters away, its controlled angle (left to right) is within 30 degrees, while the vertical angle (up to down) is within 15 degrees.

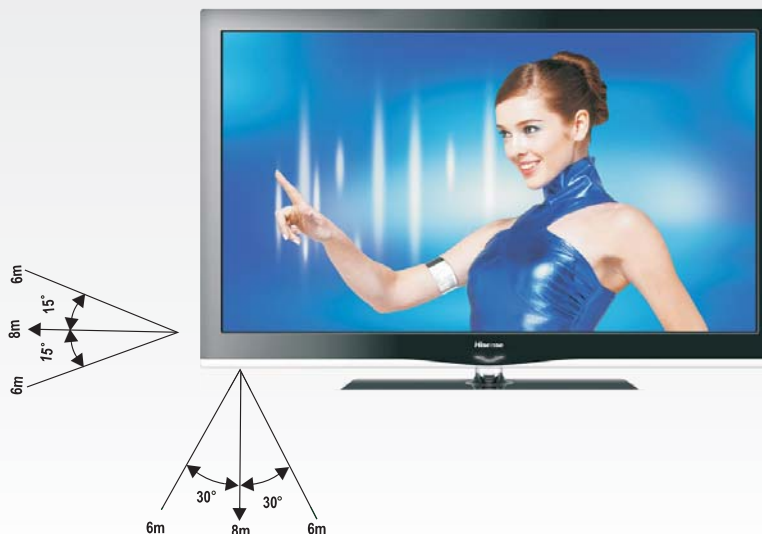

Using the Remote Control



The Remote Control Panel

The Remote Control Panel	Buttons instructions(from up to down)
<p>The diagram shows a black remote control with the following callouts: 1 (top window), 2 (indicator light), 3 (D/A Source buttons), 4 (red power button), 5 (D/A Source buttons), 6-9 (numbered buttons 1-9), 7 (Last button), 8 (Info button), 11 (FAV button), 9 (Picture button), 10 (Sound button), 13 (VOL +/- buttons), 12 (Mute button), 14 (CH +/- buttons), 15 (Menu button), 16 (EXIT button), 17 (OK button), 20 (I/I button), 18 (Zoom button), 19 (EPG button), 21 (Still button), 24 (Page up/down buttons), 22 (Browse/Rotate buttons), 25 (Audio/Subtitle buttons), 23 (Radio/T.Shift buttons), 26 (Play/Pause/Stop buttons), 28 (D/EMP/Media buttons), 27 (PVR buttons), 30 (Setup buttons: Stop, Play, Fast Back, Fast Forward), 31 (Text/Size/Reveal/Cancel/Sleep/Index/Sub.Code/Mix buttons).</p>	<ol style="list-style-type: none"> (1) Remote sensing Window. (2) Indicator glows from white to orange when buttons are pressed. (3) D/A: Digital /Analog TV. (4) Power Standby: Power button(The red big button). (5) Source: Available source selection. (6) 1,2,... numbers: For direct channel access. (7) Last: To return to the last view program. (8) Info: Display current informations. (9) Picture: Picture Mode selection. (10) Sound: Sound Mode selection. (11) FAV: Fast access to your saved favorite programs. (12) Mute: Mute the sound. (13) VOL+/VOL-: Volume Up/Volume Down (14) CH+/CH-: Channel Up/Channel Down (15) Menu:Display the main menu/Back menu display. (16) EXIT: Exit all menu display. (17) OK: Enter or confirm the operation ▲/▼/◀/▶:Up/Down/Left/Right (18) Zoom:Zoom image. (19) EPG:Electronic Program Guide (20) Still: Picture Freeze. (21) I/I: Mono/Stereo operation,Audio select button. (22) T.Shift/Rotate: Time Shift/Rotation of images on the USB device.(23) Radio/Browse: Switch to DTV Radio program. (24) Audio/Page up: select Audio language in DTV Mode/page up (25) Subtitle/Page down: Display the subtitle content of the signal/page down (26) Play/Pause: Play button - to enter and open the file - also used for PAUSING the display. (27) Stop: stops playing the slideshow (28) Media: DMP Media PVR: Start Video Recorder. (29) DMP: Enter the DMP mode. (30) In DMP mode: [◀◀] button - press to fast back in video playing. [▶▶] button - press to fast forward in video playing. [◀◀] button - press to play the previous video [▶▶] button - press to play the next video They also have other special use's in some files. (31) Sleep: sets the sleep timer of your TV. Index: Show the PVR recorded list. The other keys are not supported in this TV.

Note:The design of the remote control is subject to change and may be different from the actual one. Those buttons without comment's have no relation with this TV.



Quick starts

■ Turning your TV on and off

To turn your TV on: Connect the TV to an AC power outlet and an external antenna, then turn on the power via switch located below the front right hand side of unit. A few seconds later an image will appear on the screen. Setup wizard-select your state and press OK, Then press OK again to start the Tuning process.

- Turning off to standby mode: Press [Power Standby] on the front panel or on the remote control to switch to standby mode. You can activate the unit again by pressing [Power Standby].
- Power indicator: Red indicates standby mode. There will be no light when the power switch is in the off position.

Notes:

Turn the power switch off when you do not intend to use the TV for long periods, for example overnight. Remove the connection from the wall power outlet if you do not intend to use the unit for longer periods, for example if you plan to be away a few days. Wait at least 5 seconds after turning off if you want to re-start the TV.

■ Selecting the video source

- Selecting the video source depending on the video device you have connected to your TV.
- To select the video source:
Press [Source] . When the list of video sources appears, press [▲/▼] to select the source, then Press [OK] to enter.
[D/A] button: press the [D/A] button to switch between the Digital/Analog TV signal input.

■ Adjusting the volume

- To adjust the volume:
Press [VOL+/VOL-] to increase or decrease the volume. Press [Mute] to turn the sound off. Press [Mute] again to turn the sound back on.

■ Changing channels

- To change channels:
Press [CH+/CH-] to go to the next higher or lower channel. Or, Press the number buttons to select a channel. For example, to select channel 12, press 1, then 2. Or, press [last] to go to the last viewed channel.

■ Selecting the sound mode

- To select the sound mode:
Press the [Sound] button to select between 4 different pre-adjusted sound modes: Standard, Music, Speech, and User(configurable mode). The User mode preserves your preferred sound settings after using the Equalizer available under the Sound submenu.

■ PVR

The function is to be used in DTV source only. The format of disk must be FAT32. In [Function] menu [PVR File system], the correct disk is selected. Press the [PVR] button to begin to record the program that is live. Press [■] button to stop record and a *.mpg file will be saved. The mpg files can be played in DMP, and also can be played in DTV source by pressing [Index] button.



■ Selecting the picture mode

- To select a picture mode:
Press the [Picture] button to select between 4 different pre-adjusted picture modes: Bright, Standard, Soft and User (configurable mode). The User mode automatically preserves your personal settings after adjusting brightness, colour and contrast etc.

■ Selecting the aspect ratio

- To select the aspect ratio:
Press the [Zoom] button to change the screen aspect ratio among Auto, 16:9, 4:3, Zoom1 ,Zoom2 and Smart Zoom.

■ Freezing a picture

- To freeze a picture:
Press the [Still] button to snapshot the present Viewing picture, and press again to return to normal.

■ Setting the sleep timer

You can specify the amount of time you want your TV to wait before it automatically turns off.

- To set the sleep timer:
Pressing [Sleep] button repeatedly will allow you to change the sleep timer mode: Off, 10 minutes, 20 minutes, 30 minutes, 40 minutes, 50 minutes, 60 minutes, 70 minutes , 80 minutes, 90 minutes, 100 minutes, 110 minutes or 120 minutes.

■ Display channel information

- To display channel information.
Press [Info] view current channel information in TV/DTV source.
Press [EPG] to view channel information in DTV mode, There are INFO, Schedule, DATE and Reminder items, you can look or set them.
 - Press the INFO button to enter INFO menu.
 - Press the GREEN button to enter SCHEDULE LIST.
 - Press the Yellow button to enter DATE menu.
 - Press the BLUE button to enter Reminder menu.
Once a reminder is set, it will appear in the SCHEDULE list.

■ Audio function

- Pressing [I/II] button the TV screen will display the Audio menu, you can adjust the Mono/Stereo operation and the sound channels(L/R) .

■ Displaying channel lists

- Press [OK] to display the channel list.

Changing the TV Settings



Using the Channel Menu

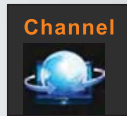

Auto Install
DTV Manual Install
ATV Manual Install
Program Edit

OK → Enter ↑↓ Select □ Return

- Press [Menu] to open the main menu.
- Press [▲/▼] to select Channel, then press [▶/OK] to enter the Channel menu.
- Press [▲/▼] to select an option.
- Press [▶/OK] to enter the submenu.
- Press [Menu] to return the up menu.
- Press [Exit] to exit

■ Auto Install

This is the easiest and most effective way to install all channels available in your area automatically.

-In both the Analog and Digital signal source

- Press [▲/▼] to select Auto Installing.
- Press [OK] start an automatic search, and this will memorize all the available channels.
Auto Tuning will take a few minutes; please wait until it has finished.

■ DTV Manual Install

-in Digital signal source

Digital channel numbers are different to the existing analog channel numbers; please contact the broadcaster in your state for more information.

- Press [▲/▼] to select the DTV Manual Tuning, then press [OK] to enter DTV Manual Tuning menu
- Press [◀/▶] to select a channel then press [OK] to search.

■ ATV Manual Install

-In Analog signal source

Manual Install is only needed when analogue channels are not found under an automatic tune.

- Press [▲/▼] to select ATV Manual Tuning, then press [OK] to enter ATV Manual Tuning menu.
- Press [◀/▶] to select a channel.
- Press [▲/▼] to select Search then press [◀/▶] to begin tuning.
- Press the red button to save the channel.

NOTE: System setting for Australia is BG.



Using the Channel Menu



■ Program Edit

After you scan for channels, you can delete a channel from memory if you want to skip the channel when you press [▲/▼]. You can still select the skipped channels using the number buttons. You can also rename the channels, lock or unlock the channels from memory.

- Delete channels: choose the Red button to delete the channels you have selected, once to select and twice to delete.
- Rename channels: choose the Green button and by using [◀/▶] and [▲/▼] to rename the channels names you have selected.
- Move channels: choose the Yellow button and press [▲/▼] to Move the channels to another position you have selected, press [Menu] to finalize the MOVE.
NOTE: "RENAME" and "MOVE" are for ATV channels only.
- Skip channels: choose the blue button to Skip the channels you have selected.
- FAV channels: choose the FAV button to add the channels you have selected to the favorite list.

Changing the TV Settings



Using the Picture Menu

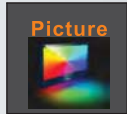

Picture Mode	Standard	
Brightness	50	<input type="range"/>
Contrast	50	<input type="range"/>
Color	50	<input type="range"/>
Sharpness	50	<input type="range"/>
Tint	0	<input type="range"/>
Back Light	100	<input type="range"/>
Color Temperature	Standard	
Aspect Ratio	16:9	
Noise Reduction	Auto	

OK → Enter ↑↓ Select ⏪ Return

- Press [Menu] to open the main menu.
- Press [▲/▼] to select Picture, then press [▶/OK] to enter the Picture menu.
- Press [▲/▼] to select an option.
- Press [◀/▶] to adjust the option or press [▶/OK] to enter the submenu.
- Press [Menu] to return the up menu.
- Press [Exit] to exit. .

- Picture Mode - Press ◀/▶ to select between 4 different pre-adjusted picture modes: Bright, Standard, Soft and User (configurable mode). The User mode automatically preserves your personal settings after adjusting brightness, color and contrast etc.
- Brightness – Increases the brightness to add more light to dark areas of the picture. Decreases the brightness to add more dark to light areas of the picture.
- Contrast – Increases the picture level to adjust the white areas of the picture. Decreases the picture level to adjust the black areas of the picture.
- Color – Adjusts the intensity of the colors.
- Sharpness – Increases the sharpness level to show cleaner and clearer images. Decreases the level to show a smoother picture.
- Tint - change the picture quality when there is a NTSC signal at AV source.
- Backlight -Adjust backlight to suit light conditions in the room. Under low room illumination, the use of lower backlight settings is recommended for reduced power consumption and extended life of the flat panel of your television.
- Color Temperature–Changes the color temperature. You can select Cool, Warm, Standard.
- Aspect Ratio - Press ◀/▶ to change the screen aspect ratio among Auto, 16:9, 4:3, Zoom1 , Zoom2 and Smart Zoom.
- Noise Reduction–Reduces video noise in moving images without blurring the picture.

Changing the TV Settings



Using the Sound Menu

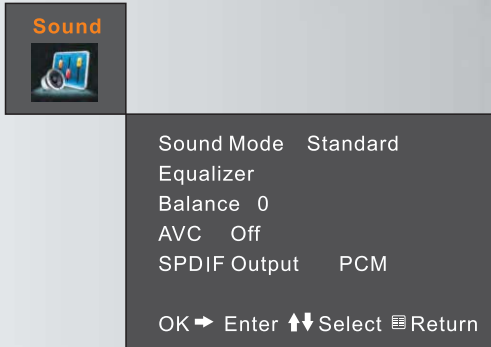

- Press [Menu] to open the main menu.
- Press [▲/▼] to select Sound, then press [▶/OK] to enter the Sound menu.
- Press [▲/▼] to select an option.
- Press [◀/▶] to adjust the option or press [▶/OK] to enter the submenu.
- Press [Menu] to return the up menu.
- Press [Exit] to exit.

- Sound Mode - Press [◀/▶] to select between 4 different pre-adjusted sound modes: Music, Standard, Speech and User (configurable mode). The User mode preserves your preferred sound settings after using the Equalizer available under the Sound submenu.
- Equalize - Set the users' mode of sound, press [◀/▶] button to select the sound component of 120HZ, 500HZ, 1.5K, 5K, and 10K. Press [▲/▼] button to weaken or enlarge the sound to the proper value.

The sound Equalizer can also be easily configured for most frequent situations by pressing the [SOUND] button on your remote controller. Preset settings are provided for User, Music, Standard and Speech conditions. Standard mode delivers a flat frequency response, which preserves the natural characteristics of the original sound. In Music mode the extremes of low and high frequencies are accentuated to enhance musical instrument reproduction. The opposite effect is accomplished in Speech mode where very low and high frequencies are attenuated to improve the reproduction and intelligibility of the human voice.

- Balance – Adjusts the volume from the left and right speakers.
- AVC: auto adjust the sound.
- SPDIF Output – Enable and disable the SPDIF optical output .

Changing the TV Settings



Using the Lock Menu

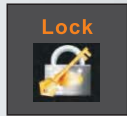

Change Password
Block Program
Parental Guidance No Block

OK → Enter ↑↓ Select □ Return

- Press [Menu] to open the main menu.
- Press [▲/▼] to select Lock, then press [▶/OK] to enter the Lock menu.
- Press [▲/▼] to select an option.
- Press [◀/▶] to adjust the option or press [▶/OK] to enter the submenu.
- Press [Menu] to return the up menu.
- Press [Exit] to exit.

When you first use this function, the default password is [0000]. Once you input this password, you can continue to the next operation.

NOTE: The factory initial password is "0000".

- Change Password - to set or change password.
 - First input a new password.
 - Second input the new password again.Note: Please store your new password in a safe place.
- Block Program - The MENU below will be displayed listing your available channels. Select the channel to block and push the GREEN button to block it.
- Parental Guidance
 - Classifies the programs into the following:
 - No Block - No programs are blocked.
 - Block R and above - All "R" rated classified programs are blocked.
 - Block AV and above - Adult audiences, strong violence, 15 years and older.
 - Block MA and above - Mature audiences only, 15 years and older.
 - Block M and above - Mature audiences only, parental guidance is strongly advised.
 - Block PG and above - Parental guidance recommended.
 - Block G and above - General audiences.
 - Block all - All classified programs are blocked.Note: If there is no classification on the broadcast, the program will not be blocked.

Changing the TV Settings



Using the Screen Menu

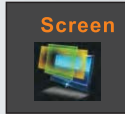

Position
H_Size 50
V_Size 50

OK → Enter ↑↓ Select Return

- Press [Menu] to open the main menu.
- Press [▲/▼] to select Screen, then press [▶/OK] to enter the Screen menu.
- Press [▲/▼] to select an option.
- Press [◀/▶] to adjust the option or press [▶/OK] to enter the submenu.
- Press [Menu] to return the up menu.
- Press [Exit] to exit.

- Image Position - Adjust the horizontal and vertical position of the image.
- H Size - Adjust the horizontal size of the image.
- V Size - Adjust the vertical size of the image.
- Clock - Adjust the VGA Clock to match the PC clock. (VGA mode only)
- Phase - Adjust the VGA phase to match the PC. (VGA mode only)
- Auto Adjust - Auto adjust the VGA image position. (VGA mode only)

Changing the TV Settings



PC Setting

PC Setting

Set the PC Software properly to match one of the below options.

Supported VGA Modes:

VGA___ (640×480 60Hz)

SVGA___ (800×600 60Hz)

XGA___ (1024×768 60Hz)

SXGA___ (1280×1024 60Hz)

Note: Your PC/Notebook may not be able to display some of these resolutions.

Take Windows XP as an example, and the Windows system display setting is as illustrated:

1. Right click anywhere on your display, select 'Properties'.
2. Find the Settings tab on the dialogue box, set the screen Resolution.
3. See above details about the resolutions supported by this unit.
4. Click OK to exit.

Please note: Primarily this unit is intended for use as an LCD TV. If compatibility is a problem when using this unit as a monitor, please contact the manufacturer of the PC Video/Graphic's card for further support. Perfect compatibility is not warranted.

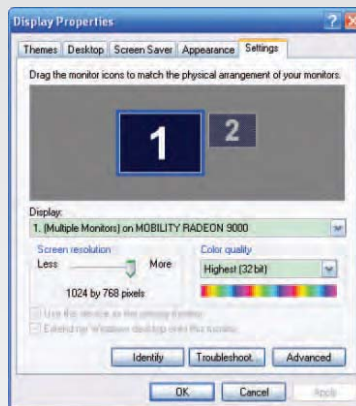



Using the DMP Menu



- Press [Source] to open Source menu.
- Press [▲/▼] to select DMP, then press [▶/OK] to enter the DMP menu.(or press [D/EMP] to enter the DMP menu.)
- Press [◀/▶] to select an option, press [OK] to enter the option.
- Press [▲/▼] to select a file, press [OK] to confirm the file is selected, press [Play/Pause] to play the file.
- Press [Exit] to return to the up menu.

DMP Browser function :

This unit incorporates a browser to view all your photos, Musics, Movies and Text files on screen.

First insert your USB device with files you wish to view into the USB port - This can be inserted while the TV is on or off.

■ Browse photos

Select the PHOTO option.

Press [Browse] to show all photos on the screen ,Press [◀/▶] to select one and press [Play/Pause] to show with slide-style.

Press [▲/▼] to select one or more photos, press [OK] to confirm, press [Play/Pause] to play.

Press [Rotate] to rotate the selected photo.

Press [Page up] to zoom in the selected photo.

Press [Page down] to zoom out the selected photo.

■ Listen to music

Select the MUSIC option.

Press [▲/▼] to select a music , press [OK] to enter, press [Play/Pause] to play the music.

Also can select more than one music at the same time, press [Play/Pause] to play all the musics one by one.

Press [◀◀/▶▶] to set the play speed "fast rewind" or "fast forward".

Press [|◀◀/▶▶|] to select preview or next.



Using the DMP Menu



■ Watch a movie

Select the MOVIE option.

Press [▲/▼] to select a movie , press [OK] to enter, press [Play/Pause] to play the movie.

Also you can select more than one movie at the same time,press [Play/Pause] to play all the movies one by one.

Press [◀◀/▶▶] to set the play speed "fast back" or "fast forward".

Press [| ◀◀/▶▶ |] to select preview or next.

■ Read a text file

Select the TEXT option.

Press [▲/▼] to select a TEXT, press [OK] to enter, press [Play/Pause] to show.

Note: File formats you can use

PHOTO: *.jpg

MUSIC: *.mp3

MOVIE: *.AVI (encoding: H.264, Mpeg, Xvid)

TEXT: *.txt

NOTE : Images, music and video files which were modified and or damaged by computer virus' or corrupted by disk data may affect proper play.



▶ Trouble shooting ■

When there is something wrong with your TV, you can try turning off the TV and then restart it. You can also operate according to the following chart. If the problem still cannot be solved, please contact the professional technicians.

Symptom	Remedy
<ul style="list-style-type: none"> • No sound or picture 	<ol style="list-style-type: none"> 1. Check if the power line is in the outlet and if it has electricity. 2. Check if you have pressed Power button on the TV or Power button on the remote control. 3. Check the setting of picture brightness and contrast. 4. Check the volume.
<ul style="list-style-type: none"> • The picture is normal, but there is no sound. 	<ol style="list-style-type: none"> 1. Check the volume. 2. Check if Mute mode is set.
<ul style="list-style-type: none"> • No picture and white or black picture. 	<ol style="list-style-type: none"> 1. Adjust Picture Setting. 2. Check Colour System.
<ul style="list-style-type: none"> • The sound and picture are interfered. 	<ol style="list-style-type: none"> 1. Try to find the appliance affecting TV set, and move it far away from the TV set. 2. Try to insert the power plug of the TV set into another outlet.
<ul style="list-style-type: none"> • Unclear picture or picture with snow 	<ol style="list-style-type: none"> 1. Check the direction, position and connection of your antenna. 2. Adjust the direction of your antenna or reset or fine tune the channel.
<ul style="list-style-type: none"> • The remote control does not work 	<ol style="list-style-type: none"> 1. Change the batteries in the remote control. 2. Clean the upper side of the remote control (radiating window) 3. Check the contacting points of the batteries. 4. Check if there is obstruction between the remote control and the monitor. 5. Check if the batteries are correctly installed.
<ul style="list-style-type: none"> • H/V strip or the picture shaking 	Check if there is interfering source nearby, such as appliances or electric tools.
<ul style="list-style-type: none"> • The TV cabinet makes a "Clicking" sound 	This happens due to room temperature change causing the television cabinet to expand or contract This is normal, and shouldn't cause alarm.
The motion is unstable	Try changing the MEMC settings to suit. * Refer to our website FAQ's for further notices
The DMP function not working	Images, music and video files which were modified and or damaged by computer virus' or corrupted by disk data may affect proper play. + Check the USB devices for corruption. +



Specifications

Model	HL19T28L	HL22T28PL
Screen Diagonal Size	19 inches LED	22 inches LED
Screen Resolution	1366X768 Pixels	1920X1080 Pixels
Power Consumption	25W	25W
Power Supply	AC 50/60Hz 220-240V	
Colour System	PAL/NTSC	
Television System	PAL B/G DVB-T	
Sound Output (RMS)	2W+2W	
Component mode	(480I/60Hz, 480P/60Hz, 576I/50Hz,576P/50Hz,720P/50Hz 720P/60Hz,1080I/50Hz,1080I/60Hz,1080P/50Hz,1080P/60Hz)	
VGA mode	(640X480, 800X600,1024X768,1280X1024 60Hz)	
HDMI mode	(480I/60Hz, 480P/60Hz, 576I/50Hz,576P/50Hz,720P/50Hz,720P/60Hz, 1080I/50Hz,1080I/60Hz,1080P/50Hz,1080P/60Hz) (640X480, 800X600,1024X768,1280X1024 60Hz)	
Size without base(mm)	486mm×340mm×35mm	549mm×376mm×35mm
Size with base(mm)	486mm×392mm×160mm	549mm×425mm×160mm
Weight without base(kg)	4	5
Weight with base(kg)	5.2	6.2
Environmental	Temperature 5°C~35°C	
Conditions	Humidity : 20%-80%RH	
Humidity : 20%-80%RH	Atmospheric pressure: 86kPa-106kPa	

Note: Hisense is committed to continued product improvement which may result in changes to specifications and appearance without previous notice.

HL19T28L HL22T28PL

Hisense[®]

[Http://www.hisense.com.au](http://www.hisense.com.au)